

MAE 2250 Spring 2022

Water Pump Final Report

Tuesday (Lab 421) Group 3

Sebastian Pardo

Samara Hatley

Nila Narayan

Charlie Bierden

Griffin Weaver

John Dowd

Runxuan (Daniel) Li



Figure 5: Orthographic Render

Table of Contents

System Overview and Design Process	3
Pump and Mode of Action	3
Justification and Process of Design Choice	3
Challenges Faced	6
Performance Analysis	7
Detailed Design	8
CAD Renders	8
Exploded View	9
Finite Element Analysis (FEA)	10
Analysis	11
Functional Decomposition	11
Morphological Chart	12
Power Calculations	13
Manufacturing and Fabrication Process	14
Manufacturing Plan	14
Parts To Be Ordered	16
Bill of Materials	16
Production Costs	17
Fabrication Timeline	18
Appendix	21
Graphics	21
Sketches	23
Part Drawings	27
Other Calculations	31
Timelines and Team Calendar	32
Notes on Team Charter	33

System Overview and Design Process

Pump and Mode of Action

This design is a single piston pump that uses a slider-crank mechanism to translate rotational motion into reciprocating linear motion. First, a crank bar with multiple threaded holes is fixed to the motor shaft. Then, a two-bar linkage connects to a pivot point on the piston head. The length of the crank lever arm can be adjusted by screwing the linkage into the appropriate hole on the crank bar. As the piston is pulled back, the tight tolerance allows it to draw water from the reservoir into the cavity. Then, on the return stroke the piston forces that water through the outlet hose and up to the receptacle. The pump dimensions were designed to satisfy the 1 liter/min specification using any possible crank length, with a reasonable safety factor. This gave us the ability to change the torque/velocity ratio as needed on Test Day. More specific calculations will be included later in this report.

Justification and Process of Design Choice

The primary design goal was to pump 1 Liter of water in one minute while being within the volume and area requirements. In addition, we wanted to create a simple yet very well-made pump to hit that goal. The design process followed a theme of sequentially making decisions from most broad to most specific. This process is outlined below.

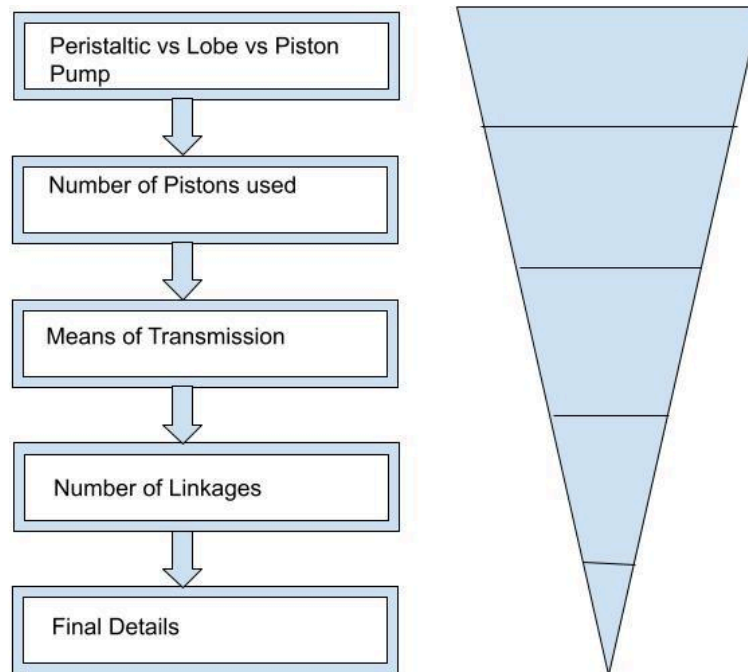


Figure 1: Design Process

This piston pump design was chosen because it stood out as most effective when compared to the Peristaltic and Lobe pump designs. To achieve the desired flow rate with a peristaltic pump, calculations showed the rotational frequency of the rollers must be considerably higher than the speed at which the shaft rotates (Figure 2). Therefore the design would need a transmission which, given the machining capabilities available, would be difficult to manufacture. When analyzing the feasibility of a lobe pump, again, machinability was an evident issue. The precision and CNC techniques necessary to create lobes with enough clearance to pass each other but not too much to break the seal seemed unrealistic for our timeline and budget. This made the piston pump most appealing as it could meet our flow requirements without difficulty, while the parts were all within our manufacturing abilities.

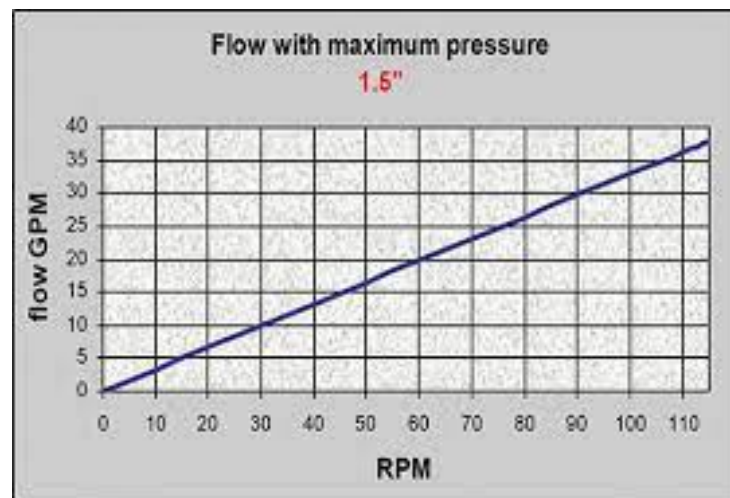


Figure 2: Example RPM vs Output of a Peristaltic Pump linear relation
<https://www.pumpsandsystems.com/peristaltic-pump-speed-considerations>

Once the piston pump was decided to be most effective, we moved on to the specifics of the design. The main decisions to be made were using either one or two pistons, as well as the power transmission from the rotating motor shaft to the reciprocating piston head. According to the calculations computed in the Design Phase, a single piston would suffice to hit the target flow rate. It would also lighten the manufacturing load, so we could spend extra time perfecting that one piston in keeping with our overall theme of simplicity with high quality.

A similar thought process was undertaken when designing the power transmission. A scotch-yoke and a Cam were both considered for this. A scotch yoke seemed like a strong option but the machining needed to create the yoke seemed beyond the realm of the team and equipment. In addition, the ability of the scotch-yoke to power two pistons simultaneously was not needed. There was also the concern that it would introduce extra friction into the system, reducing efficiency. The idea to CNC this part was considered but ultimately shut down because of the high price. A Cam design was also considered but it would be challenging to create one of the right size and shape. It also required a separate retraction mechanism for the piston head, since neither the Cam nor gravity could not provide this pulling force in the horizontal configuration. The slider-crank mechanism offered solutions to these problems in its feasibility and reliability.

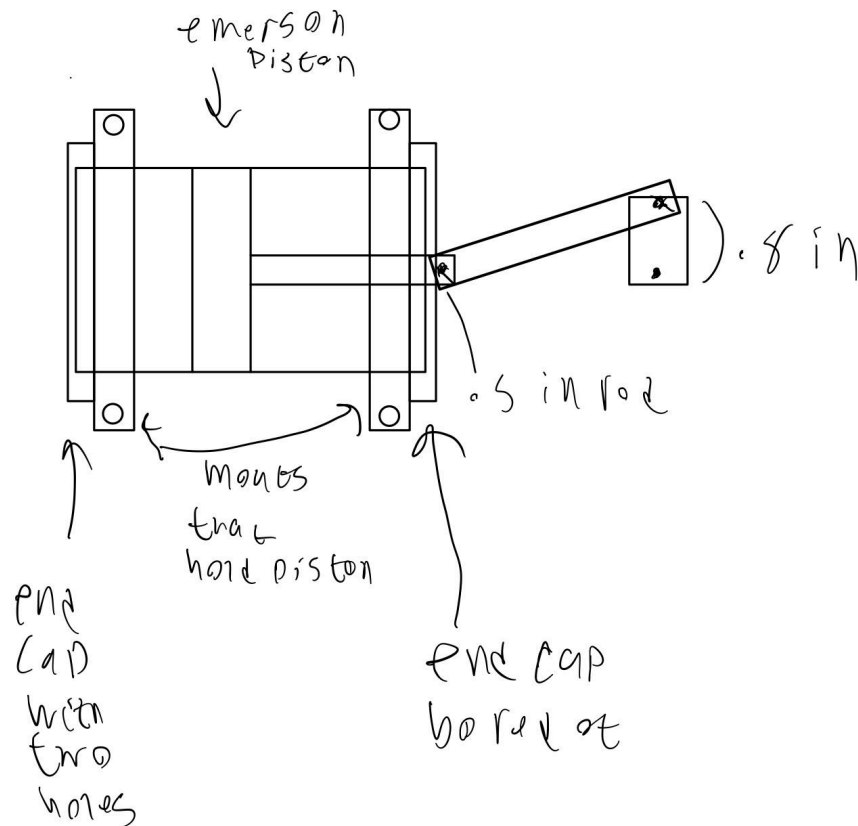


Figure 22: Preliminary Sketch of Piston Pump

When designing the linkage for the slider-crank, a decision was made regarding the number of linkages used to translate the piston head. Originally, the plan was to manufacture two linkages between the crank and the piston head. The linkage connected to the head would remain horizontal and would be rigidly joined to the piston head, while the other would sinusoidally rotate with the crank. The rationale of this design was to simplify the calculations needed for how long the stroke could be without the linkage hitting the top of the fixed cylinder size. However, as the design matured it became clear that having just one linkage connected directly to the piston head would reduce the number of parts in the assembly, thus reducing the likelihood of error as well as limiting opportunities for the mechanism to jam. The endcap closest to the shaft could be specially machined using the mill to successfully fit the linkage as well, and thus, the design was changed. A side-by-side comparison is shown below of the two designs for clarity.

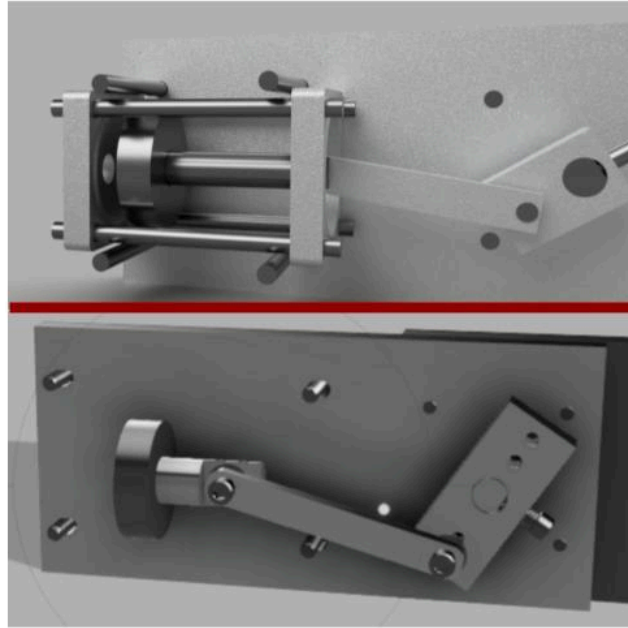


Figure 3: Original 2 Bar Linkage (top) vs Pivoting Head (bottom)

Final details of the design were thought through such as the orientation of bolts, the device to mount the piston cylinder in place, and how to ensure the water could successfully flow in and out. Morphological charts and functional decompositions helped make decisions with these components, as shown in Figures 4 and 5, found later in this report and located in the Appendix. A sequential process was followed consisting of going through each element of the chart, thinking about what the goal of the part is, then brainstorming all the ways to satisfy this goal. This is the main reason that the pump was efficiently built and executed as it was designed to do.

Challenges Faced

There were many challenges that the team encountered while manufacturing and constructing the water pump. One of the biggest challenges came from trying to determine how exactly to manufacture specific parts. For example, the cylinder assembly had square pieces that required large holes to be cut out of them. No one in the group knew exactly how to go about drilling the hole out since it was too big for any normal drill bit to do it, and at one point we had a really messy hole in the metal stock that would not have been able to correctly support the piston bar as it moves. To overcome this, the group utilized the TAs in the machine shop and collaborated with one another to figure out how to make the hole more so as it was designed. Doing this took much more time than expected, but everyone in the group made an effort to step in and help either with the part or with other aspects of the project to make sure it keeps moving along.

Another challenge faced was time management during the end of the project as it was realized somewhat late that the whole pump needed to be assembled and in the box a week earlier than expected. The group thought that there were two weeks left at one point to finish manufacturing and assembling and therefore still had about three more important parts that needed to be manufactured.

When it was discovered that there was only one week instead of two, the group had to figure out when to manufacture and reevaluate the timeline to get the pump done in time. At the end of that lab section, the group sat together and planned exactly when the parts would be manufactured during that week and who would be helping with which parts to expedite the process. More machine shop time slots were booked that week at less than ideal times since a lot of slots were already taken, but the group made sacrifices in order to finish.

Performance Analysis

The goal of this water pump project was to pump at least one liter of water in one minute on the testing day at the end of the semester. This pump was able to be tested twice, with slight modifications made between each performance. For the first test, the pump was constructed as designed and tested with little expectation for it, as there were various smaller design modifications that were able to be made on testing day based on the performance of the pump after the first test. The pump performed exceptionally well, pumping over double the goal amount of water by pumping approximately 2.2 liters of water into the bucket. However, the group knew there were ways that the pump could increase its performance and pump more water.

Some ways to make that happen were not possible, as our pump was designed with only one input and one output and we were constrained in the RPM of the motor, so increasing the number of pumps per minute was not an available solution. Instead, the group put an o-ring on the outside of the piston head to try and create more suction inside of the piston to collect more water. This would also help to decrease leakage, which was another primary issue seen with our first run.

An increase in suction was definitely created, but it made the piston head a very tight fit inside of the piston and required more torque from the drivetrain in order to move the piston back and forth. When put up for the second test, the pump lasted 50 seconds before it stalled the motor as the piston head got stuck inside of the piston. From the 50 seconds, the pump was able to pump approximately 2.2 L of water which equates to about 2.58 L of water pumped in one minute. Although the pump performance improved as the pump was able to pump more water in one minute, the pump can only operate for 50 seconds with the o-ring on, which was not what was requested by the "user".

Overall, it can be said that the pump is a successful pump as it does pump over one liter of water in one minute. The first performance is the better performance of the two as it pumps over the goal amount of water and it operates for the full minute. Although the second pump performance pumped more water, it stalled the motor and in this case, pumping less water for the full minute is more successful than potentially pumping more water in one minute only if the motor does not stall. Next time, the group would either try and shave down the piston head slightly so it is not as tightly fit inside of the piston, or the group would experiment with the multiple holes created on the crank bar to see if a longer stroke is feasible and if so, if it pumps more water.

Detailed Design

CAD Renders

Below are four CAD Renders downloaded from AutoCad Fusion 360. Each render is captured from a different angle in order to fully encapsulate the design. These renders proved to be helpful in both the design and manufacturing process. When designing the pump, certain logistical decisions had to be made such as where bolts should be oriented and how specific parts would fit together. Without these renders, this visualization of the end product would be very challenging. The renders also aided in the manufacturing process as it was very clear which part went where. In real time when handling many parts and thinking about how they could fit together, having a life-like image of the end product was very helpful.

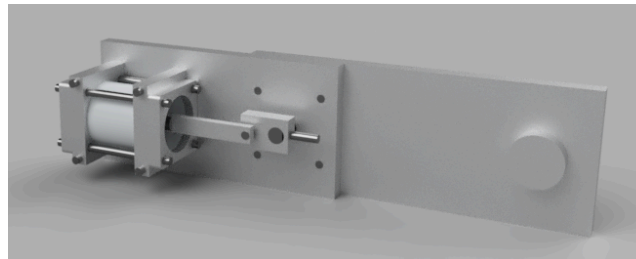


Figure 4: Orthographic view



Figure 5: Orthographic view #2

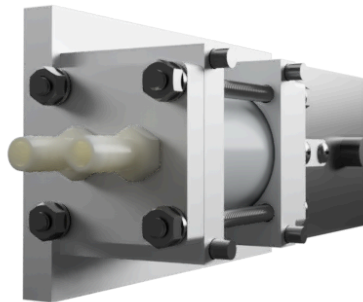


Figure 6: Render of tubing connection

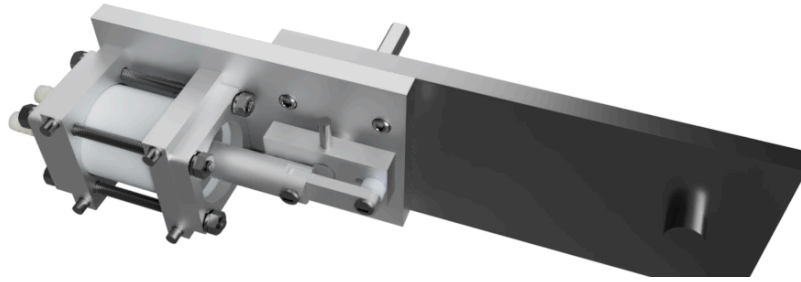


Figure 7: Render Top Down

Exploded View

Below is an exploded view of the pump, generated with CAD. This view is helpful as it shows each component of the design separately and shows how they fit together for the final product. This, again, aids in the visualization and optimization of design, as well as giving clear information to a manufacturer.

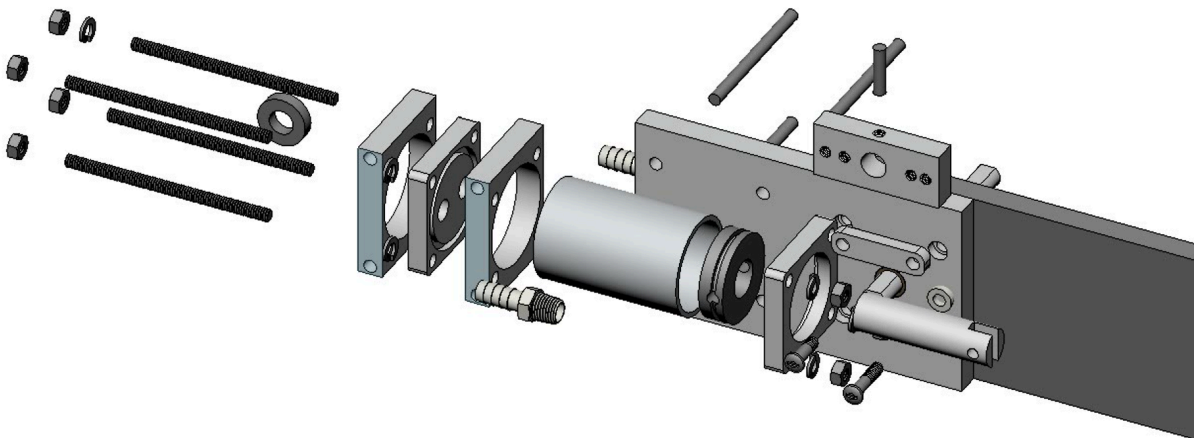


Figure 8: Exploded View

Finite Element Analysis (FEA)

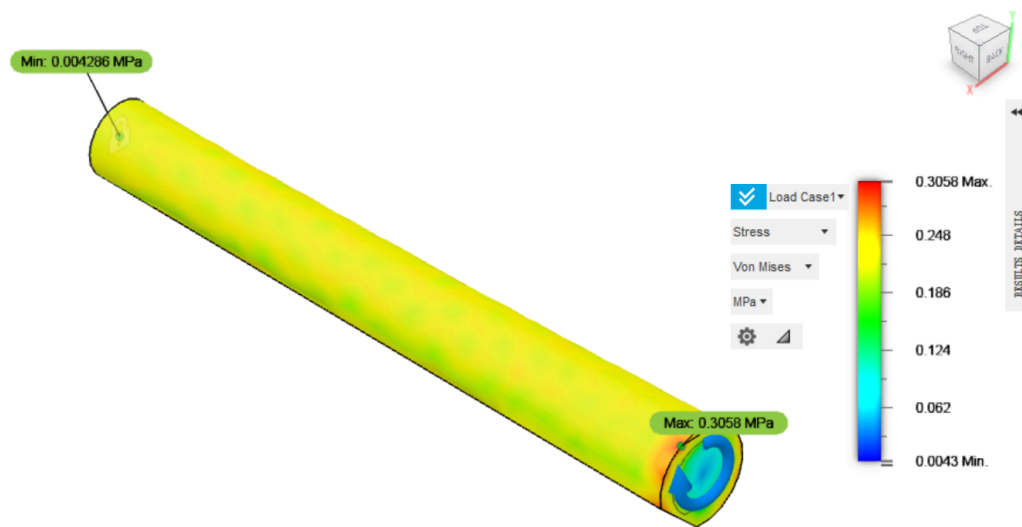


Figure 9: Stress Distribution in the Shaft

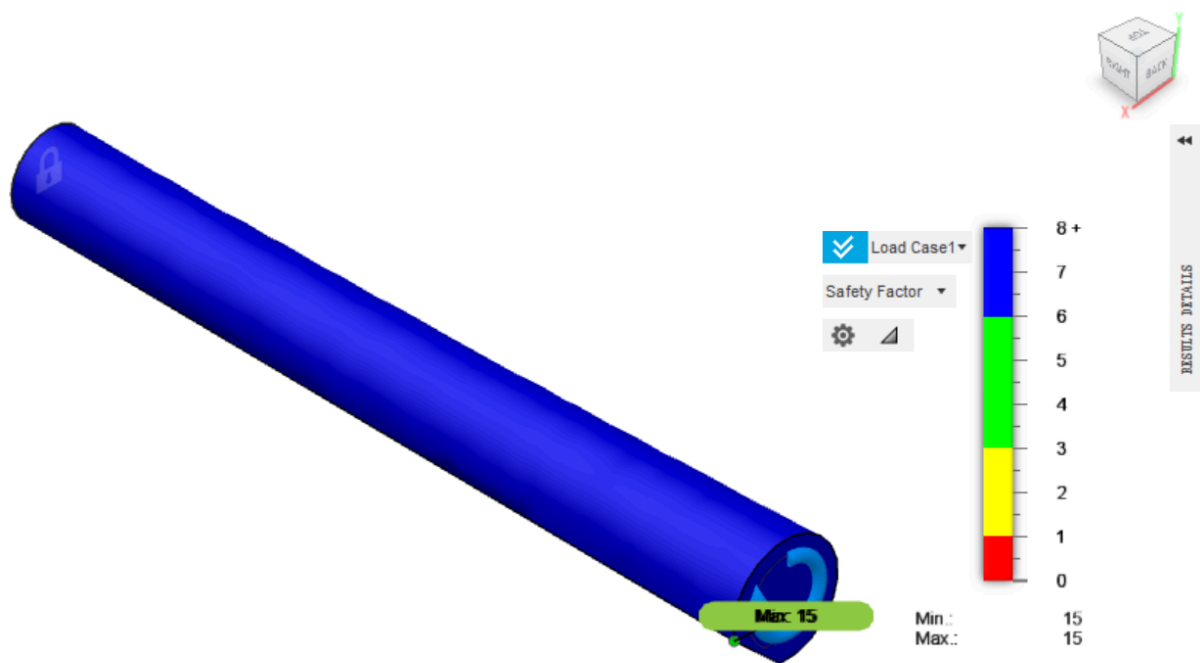


Figure 10: Safety Factor Evaluation at All Locations in the Shaft

In order to ensure safe and stable operation of our design, a stress and safety factor analysis was conducted using the analysis feature in Fusion. The part under analysis was selected to be the shaft,

which is supposed to be where the torque is the highest in the system due to the nature of transmissions we have, which magnified torque from the motor with a large gear attached to the shaft. A worst case scenario under which stress in the shaft would be the greatest, where the shaft is completely obstructed from motion, was assumed (in the model this is represented by a fixing one end of the shaft), and a torque calculated from the motor torque and transmission was applied to the unfixed end of the shaft model. Fusion then automatically generated the mesh for finite element analysis and performed the iterations, after which the result shown in figures above was obtained. Apparently, the result indicate that the system was very safe. A maximum stress of 0.3 MPa is well below any of the material constraints, as seen in the safety factor analysis where the safety factor against stress failure is greater than 8 across the entire shaft. This ensures the validity of our pump model and it also means we would not need to put much emphasis on safety in finalizing our design.

Analysis

Functional Decomposition

The functional decomposition for a piston pump lists the different parts that must be taken into consideration when designing a piston pump. Though things like controlling water movement, the piston plunger, and mounting are important to consider, and as such are listed here, they are not items that warrant being included in the morphological chart below as they are already given, like the check valves for water, or are something that must fit into the design rather than being designed around, like mounting.

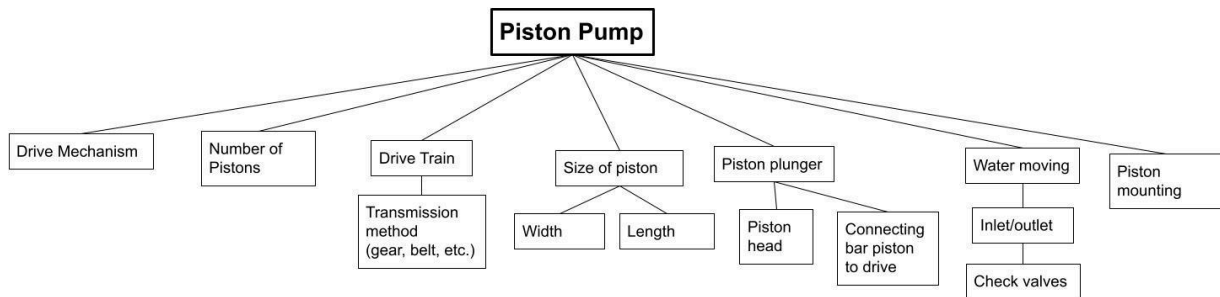


Figure 11: Functional Decomposition

Morphological Chart

Morphological chart for our piston pump. We decided to use the top option in each column. This exercise helped visualize the many different components and objectives that came along with designing the pump. Having a graphic to categorize each part and analyze its function was strongly beneficial.


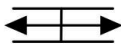

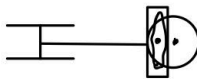

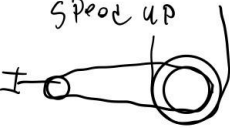



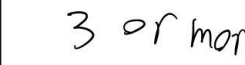

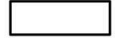

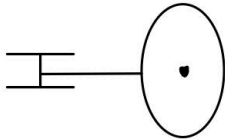
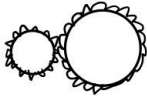


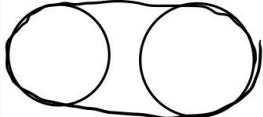


Drive mechanism	# of pistons	Drive train	Size of piston
Crank 	1 	Direct 	Standard emerson piston
Scotch yoke 	2 	Speed up 	Larger diameter   Custom Standard
rotating piston 	3 or more 	Torque up 	longer longer   Custom Standard
cam 		Gears 	Smaller diameter   Custom Standard
		Pulley/belts 	Shorter longer   Custom Standard

Figure 12: Morphological Chart

Power Calculations

The power from the motor is 0.75HP, meaning all of our configurations fall within this parameter.

MathJax

\bar{P} = Power, ρ_w = Density of water

g = Acceleration due to gravity, h = Height water is pumped,

r = Length of crank, ranges from .6in to 1.1in

$$\bar{P} = \rho_w g h \dot{Q}$$

$$\rho_w = \frac{1kg}{liter}, g = 9.81 \frac{m}{s^2}, h = 1.5m, \dot{Q} = 9.44r \frac{Liter}{min}$$

$$\begin{aligned} \bar{P} &= \frac{1kg}{liter} \cdot 9.81 \frac{m}{s^2} \cdot 1.5m \cdot \frac{9.44rliter}{min} = 138.91r \frac{kg \cdot m^2}{s^2 \cdot min} \\ &= 138.91r \frac{J}{min} = 138.91r \frac{J}{min} \cdot \frac{1min}{60s} = 2.32rW \frac{J}{s} = 2.32rW \\ &= 2.32rW \cdot \frac{HP}{746W} = 3.1r \cdot 10^{-3} HP \end{aligned}$$

$$r = .6in, \bar{P} = 1.86 \cdot 10^{-3} HP, r = .8in, \bar{P} = 2.48 \cdot 10^{-3} HP$$

$$r = 1in, \bar{P} = 3.10 \cdot 10^{-3} HP, r = 1.1in, \bar{P} = 3.41 \cdot 10^{-3} HP$$

Manufacturing and Fabrication Process

Manufacturing Plan

All parts of our water pump were designed to be manually machined or purchased from the Emerson Shop or McMaster. No CNC machining, 3D printing, or laser-cutting was required.

Only a few parts needed the lathe, namely: the piston head (both iterations), piston head rod (initial cuts to size), and the motor shaft (initial cuts to size).

We chose to machine those parts on the lathe due to their round nature. The piston head, for example, was fully round and also had a groove across the entire circumference. It made the most sense to manufacture this using the lathe, which relies on rotational symmetry.

The following parts were manufactured using a manual mill: the baseplate, left and right cylinder mounting bars, left and right end-caps (that is, modifications were made to the purchased Emerson endcaps), crank-bar, pivoting linkage, as well as the keyway in the piston head rod.

The mill was chosen for these parts because they were rectangular in nature. Without manufacturing a separate mounting piece, they would not be able to be held in the lathe, anyway. Beyond this, given the sharp corners of these pieces and fairly simply located holes, it made the most sense to manufacture these pieces on the mill since only a few bits would be needed and the process would be repetitive.

In addition to the above two machines, the bandsaw and belt-sander were also used for some parts. The bandsaw was used to make preliminary cuts of stock (thus avoiding spending hours facing down a piece of stock to the correct size), while the belt-sander was used to create a rounded edge on the crank-bar.

All shop drawings (which can be found in the Appendix) were designed in a similar fashion. A datum point was chosen for all of the dimensions to be based on, for simplicity once in the machine shop. The reasoning behind this was to maximize efficiency, as by reducing the number of origin points, the machinist would be able to avoid over-using the edge-finder (this, in turn, aided our accuracy by avoiding human error, because the machinist must also remember to correctly offset the edge-finder each time).

Beyond this, every part drawing had a step-by-step manufacturing plan printed on it. The intention behind these plans was to provide each team member with a basic guideline as to how to make a part, outlining the tools that they would need in order to make certain holes or cuts, as well as a suggested order of operations. While this was not a strict set of instructions, the goal was to avoid anybody going into the shop underprepared.

As a group, we tried to sign up for shop shifts together wherever possible, or be available in order to accompany a peer to the shop (even if we were not machining anything ourselves). This gave us the opportunity to provide support wherever necessary, and we found that it greatly helped the process.

Regarding the order in which we manufactured the parts, we more or less fabricated parts in the order in which we hoped to assemble them. That is, the piston assembly was prioritized, and the baseplate was meant to be adjusted to fit that assembly, rather than the other way around. This is because we wanted to minimize any slop in the piston assembly itself and prevent leakage. The baseplate was a more flexible piece in this matter, so while four holes were initially drilled for the endpieces, the drawing was designed to also describe how to make them into slots. As it so happened, all but two holes ended up aligning with the piston assembly based on the original holes, anyway, and the two misaligned holes were turned into slots as originally planned.

There were two parts that ended up being re-machined, but for different reasons. Firstly, the piston end-cap was remade in order to support an o-ring. In this case, re-machining was not strictly necessary, but rather was a choice due to the fact that we had extra stock.

The other piece that needed to be re-machined was the left end-piece. In this case, we re-machined the part out of necessity, because the holes ended up shifting in both the x and y direction, after not properly zeroing the edge-finder. Thankfully, this ended up being a minor roadblock as we had extra stock on hand due to the expediency of the Emerson shop.

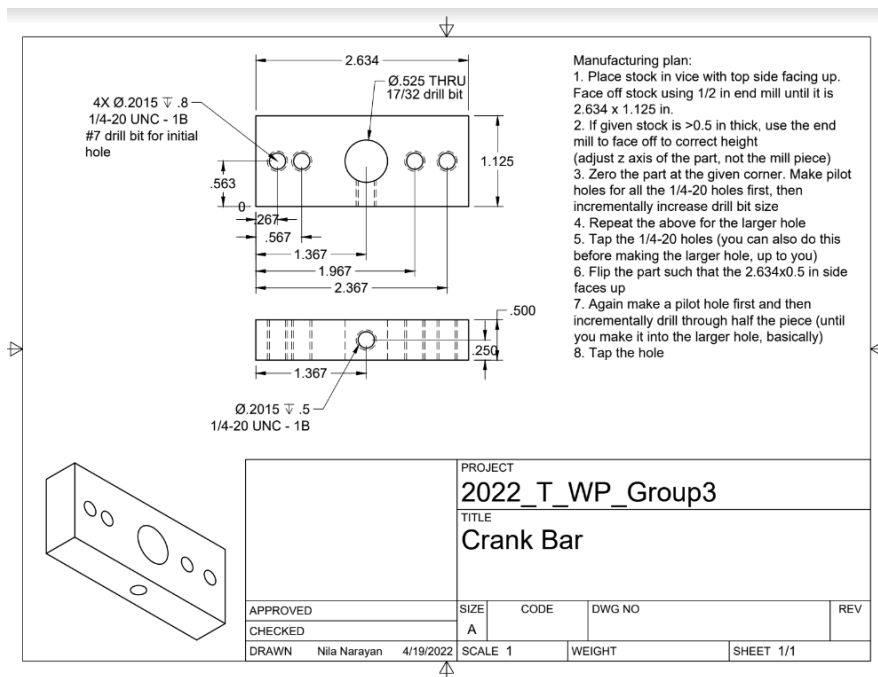


Figure 13: An example part drawing and associated manufacturing plan. All part drawings can additionally be found in the Appendix of this report.

Parts To Be Ordered

In our design, the principle we followed when considering stock parts versus custom machining was that we would prefer using stock parts in most cases. The reason is that first of all, considering the very limited amount of time we have for manufacturing, using stock parts in more places means we would be able to save more time for assemble, testing, and troubleshooting. Moreover, mass-produced stock parts are better than those machined by us in terms of their precision, so we would have less issue when assembling the pump. However, another important point is that we would not make design changes that would impact the effectiveness of our pump only because we want to avoid machining a certain part. Or in other words, we would design around a stock component only if we could prove that specifications could be satisfied with such a design. With those two principles, we decided on which parts we would machine and which to order.

As for the choice between Emerson and McMaster stock parts, we decided to order from Emerson if possible since parts from the Emerson shop are generally cheaper than those we found on McMaster and Emerson parts are prepared for this specific project, but there did exist parts that we could not find in Emerson, so we ordered those from McMaster instead. To be more specific, we used Emerson stock for piston cylinder, endcup with holes, fittings, nuts, washers, screws, and bushings. For some of those parts, such as the cylinder, the endcup, and the fittings, they are too challenging and time-consuming to machine. For the others, using stock components for those parts would, once again, be more efficient, and designing around those components has very little impact on our design. As for McMaster orders, we initially decided to order two parts from McMaster, which are the two spacers we would use to make sure the linkages in the piston system align. While it was technically possible for us to machine those parts from bulk material in the machine shop, we believe that it would be very inefficient as those parts are readily available on McMaster and we would still be well below our budget. A later addition to our list of McMaster purchases was a dynamic seal, which was impractical for us to make with the resources we have. As a result, our final McMaster order contains three parts, two spacers and one dynamic seal.

Bill of Materials

MCMMASTER-CARR PARTS					
Description	McMaster Code	Quantity	# Extra	Unit of measurement	Total Cost
Nylon Unthreaded Spacer, 1/2" OD, 3/8" Long, Black	90176A157	1	0	Pckg of 25	\$ 3.56
Off-White Nylon Unthreaded Spacer, 1" OD, 1/4" Long, 1/2" Screw Size	94639A264	1	0	Pckg of 25	\$ 8.06
High-Stability High-Speed Piston Seals, 1 3/4" Bore, 1.443" Groove	1716N14	1	0	by part	\$ 6.79
McMaster Total					\$ 18.41

EMERSON LAB PARTS			
Description	Quantity	Unit of measurement	Total Cost
1/4" x 1" Aluminum Bar	4	in	\$ 0.56
1/2" x 2 1/4" Aluminum Bar	10	in	\$ 7.30
1/2" x 4" Aluminum Bar	9	in	\$ 10.62
1/2" Dia Steel Rod	6	in	\$ 1.38
3/4" Dia x 6" Aluminum Rod	1	ea	\$ 2.50
1 7/8" Dia Plastic Rod (piston head)	2	in	\$ 1.72
1/4" - 20 threaded rod	2	ft	\$ 2.04
1/4" - 20 hex nuts	10	ea	\$ 0.60
1/4" flat washers	4	ea	\$ 0.08
1/2" ID x 13/16" OD x 1/2" Bronze Bushing	1	ea	\$ 0.60
1/4" Lock Washers	10	ea	\$ 0.20
Nylon Pipe Fittings	2	ea	\$ 1.10
1/4" - 20 allen socket head cap screw (1/2")	4	ea	\$ 0.60
1/4" - 20 allen socket head cap screw (1")	10	ea	\$ 1.70
Machined End Caps	2	ea	\$ 2.00
Bored Cylinder, 3"	1	ea	\$ 1.00
Emerson Total			\$ 34.00

Production Costs

Total Prototype Cost				
NRE design hours	NRE Cost (\$120/hr)	Prototype Hours	Prototype Cost (\$40/hr)	Material Costs (Emerson + McMaster)
4	\$480	11.833	\$473.32	52.41
			Total	\$1037.41

Type of Part/Operation	Quantity
\$1.20/unit	
Holes	35
Threadings	13
Reamings	0
Milled Flat Surfaces	
Curved Surfaces	0
\$10.20/unit	
Inches of Weld	0
Cuts	3
Hand Finished Surfaces	0
Bends	0
Prototype Cost (see above)	\$1037.41
Single Production Pump	
\$1125.61	
Production Costs if 1000 Pumps Sold	
\$89.24	

Fabrication Timeline

Below is the original fabrication timeline that we created for the water pump. The goal was to manufacture the water pump in three different parts: the cylinder assembly, the mounting, and the drivetrain. There was some confusion as to when the pump needed to be fully assembled and essentially completed, so towards the end of our timeline deadlines were pushed up. The whole device needed to be assembled by May 3rd, so the drivetrain, as well as everything else, had to be completed earlier than that. The team worked hard to schedule some more hours in the machine shop and go in on weekends to complete the parts in time. It helped greatly that all the parts and stock were ordered early and team members started early with machining so more parts or stock could be ordered if necessary.

The team kept track of their progress using a modified Gantt Chart alongside the fabrication timeline where the team highlighted the parts being ordered and manufactured by color based on their progress. Green was completed, yellow was still working/in progress, and red was not yet started. There was also a time estimate listed next to all of the parts so the team knew which parts (of the three sections of the pump) should be started first. The darker the red the more time it is estimated to take to complete. Most parts took longer than expected, which led to a few more hours in the machine shop. Team members tried to go in and help other team members who were having difficulty finishing their part or did not have as much experience in the machine shop. Underneath the fabrication timeline is the completed Gantt chart.

Fabrication Timeline:

Sunday	Monday	Tuesday	Wednesday	Thursday	Friday	Saturday
4/17	4/18	4/19	4/20	4/21	4/22	4/23
		A9: FDR Presentation - Place orders for GIVEN group - Place orders for Blanks and Stock we need	Start or ASAP: - Machining cylinder assembly - Machining #6 Our mounting plate - Picking up stock items for CYLINDER ASSEMBLY and MOUNTING	Machining	Machining	Machining
4/24	4/25	4/26	4/27	4/28	4/29	4/30
Machining	Machining	By end of lab Finished Machining: - CYLINDER ASSEMBLY - MOUNTING	Start or ASAP: - Machining DRIVE TRAIN	Machining	Machining	Machining
5/1	5/2	5/3	5/4	5/5	5/6	5/7
Machining	Machining	By end of lab Finished Machining: - DRIVE TRAIN	Start or ASAP: - Test fitting components - Troubleshooting	Assembly	Assembly	Assembly
5/8	5/9	5/10				
Finished: - Working Assembly	Troube-shooting	A11: Final Water Pump Testing				

Modified Gantt Chart:

Part #	Group	Part Name	Quantity	To Do	Estimated (min)	Actual (min)
1	GIVEN	Provided plate (Drawing on Canvas)	1	Complete order form, pick up on time	5	5
2		Endcap with two holes	1	Complete order form, pick up on time	5	5
5		Cylinder	1	Complete order form, pick up on time	5	5
23		Inlet/Outlet Fittings	2	Complete order form, pick up on time	5	5
3	CYLINDER ASSEMBLY	Endcap blank (needs hole bored out)	1	From BLANK, bore out center hole	30	60
4		Piston head	1	From BLANK, add pin hole	15	30
7		Cylinder Holding Blocks	2	From STOCK, add through holes, bore out center holes	60	90
17		Cylinder Assembly Through	4	From BLANK, cut to size	10	10

		Bolts (1/4"x20)				
18		Cylinder Assembly Nuts	4	Complete order form, pick up on time	5	5
19		Cylinder Assembly Washers	4	Complete order form, pick up on time	5	5
6	MOUNTIN G	Our mounting plate	1	From STOCK, add threaded holes, bore out motor shaft hole	90	120
20		Mounting Plate Threaded Through Bolts (1/4"x20)	4	From BLANK cut to size	10	10
14		Faceplate Mounting Screws (1/4"-20)	4	Complete order form, pick up on time	5	5
15	DRIVE TRAIN	Pin (Crankshaft to Linkage)	1	Complete order form, pick up on time	30	30
8		Crank (with multiple holes)	1	From STOCK, add threaded holes, add pin hole	30	120
9		Motor Shaft (with keyway)	1	From STOCK, cut to length, add flat side	15	30
10		Pivoting Linkage (Crank bar to piston bar)	1	From STOCK, add holes, add radius to ends	30	30
11		Piston Head Rod (Piston head to linkage)	1	From STOCK, cut to length, add pin hole and threads, and slot and holes	30	60
12		Bushing (1/2" ID, 5/8" OD, Bronze)	1	Complete order form, pick up on time	5	5
16		Pin (Linkage to Piston Head Drive Bar)	1	Complete order form, pick up on time	30	30
22		Drive Shaft Key Screw	1	Complete order form, pick up on time	30	30
24		Spacer (Crank to Linkage)	1	90176A157	10	10
25		Spacer (Motor Shaft)	1	94639A264	10	10
Total Machining Hours (Actual)						710 min 11.833 hr

Appendix

Graphics

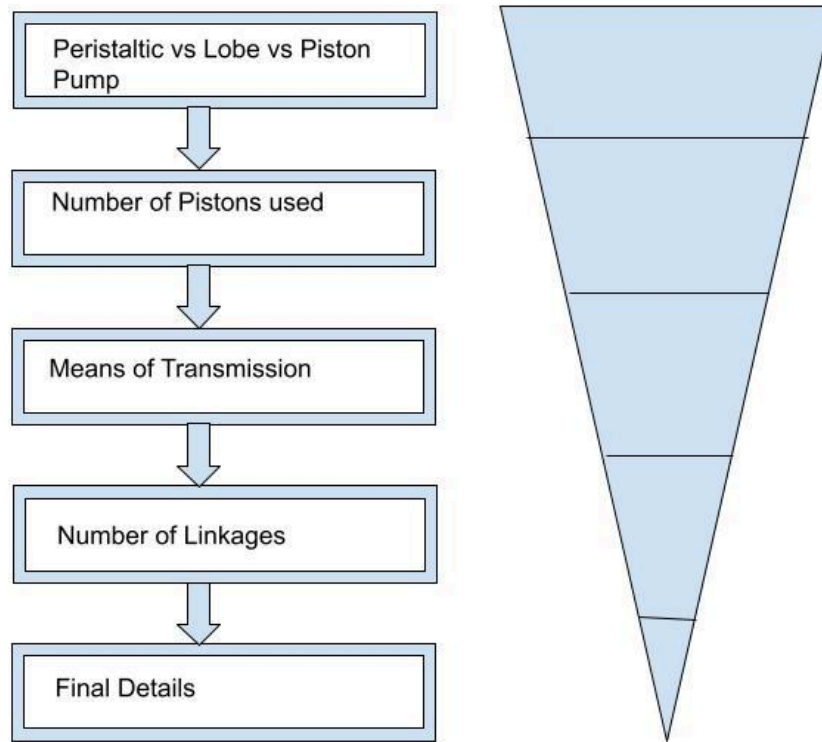


Figure 1: Design Process

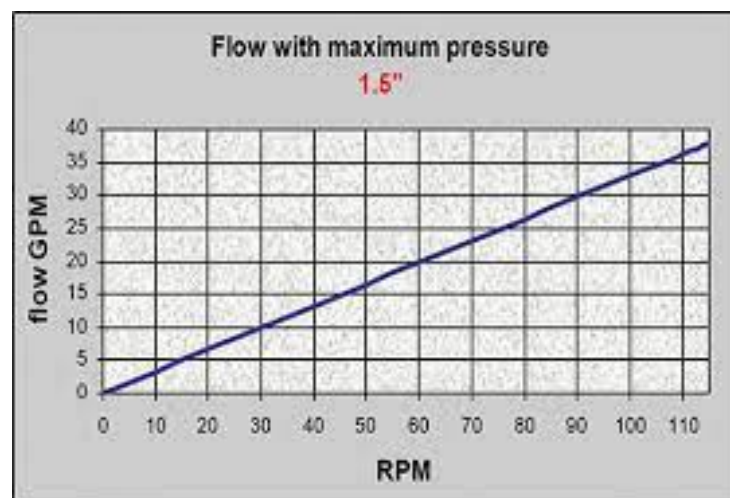


Figure 2: Example RPM vs Output of a Peristaltic Pump linear relation
<https://www.pumpsandsystems.com/peristaltic-pump-speed-considerations>

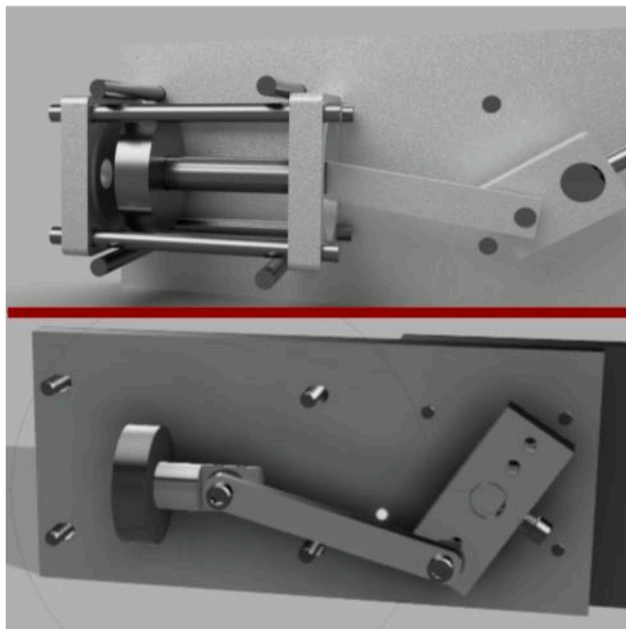


Figure 3: Original 2 Bar Linkage (top) vs Pivoting Head (bottom)

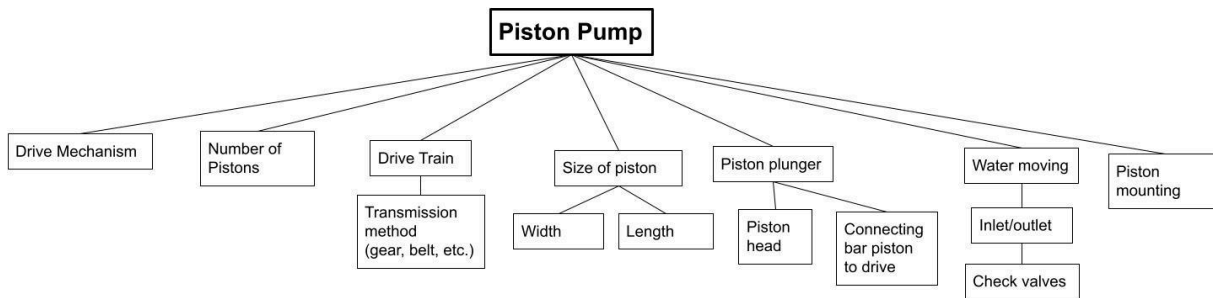


Figure 11: Functional Decomposition




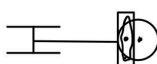
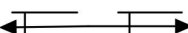
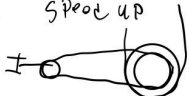
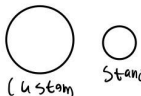




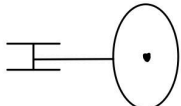
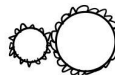

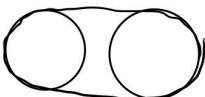
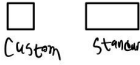
Drive mechanism	# of pistons	Drive train	Size of piston
Crank 	1 	Direct 	Standard Emerson piston
Catch brake 	2 	Speed up 	Larger diameter  Custom Standard
Rotating piston 	3 or more 	Torque up 	Longer length  Custom Standard
Cam 		Gears 	Smaller diameter  Custom Standard
		Pulley/belts 	Shorter length  Custom Standard

Figure 12: Morphological Chart

Sketches

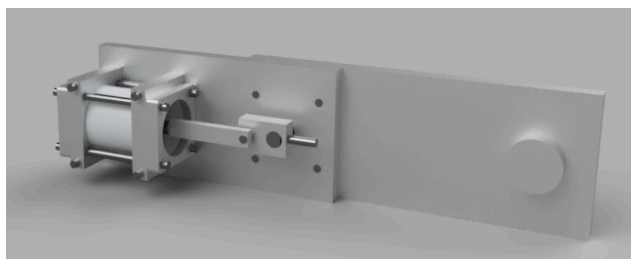


Figure 4: Orthographic view



Figure 5: Orthographic view #2

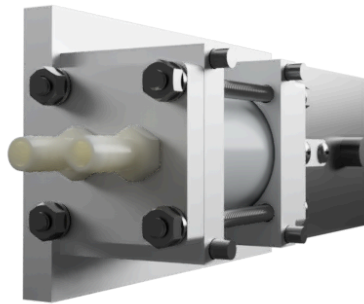


Figure 6: Render of tubing connection

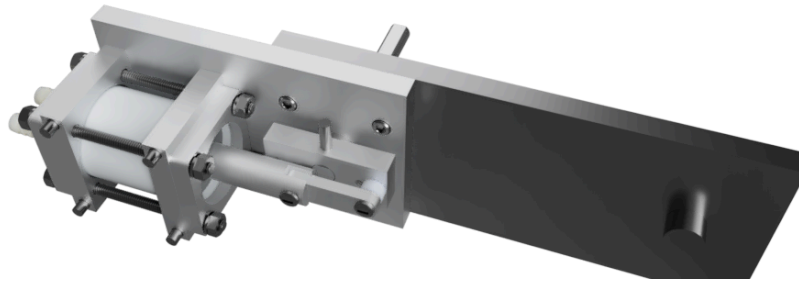


Figure 7: Render Top Down

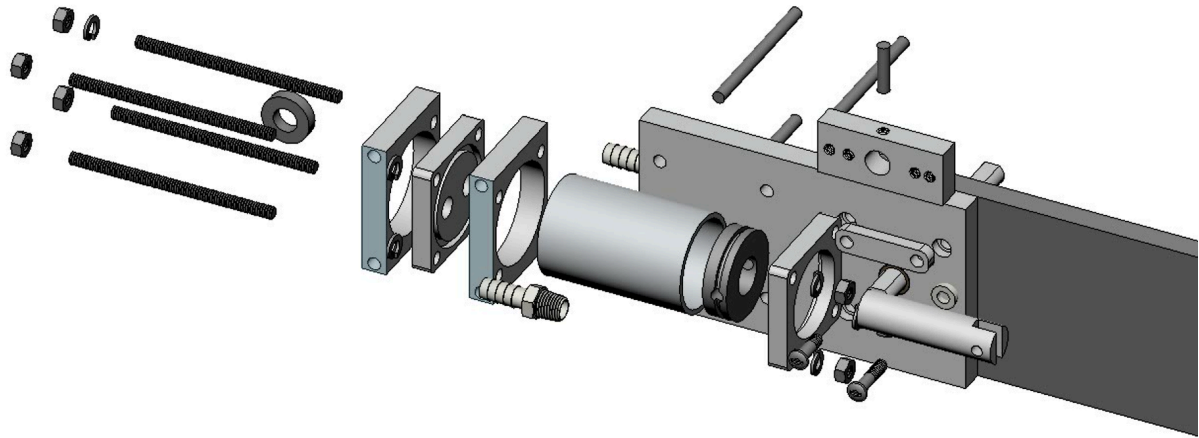


Figure 8: Exploded View

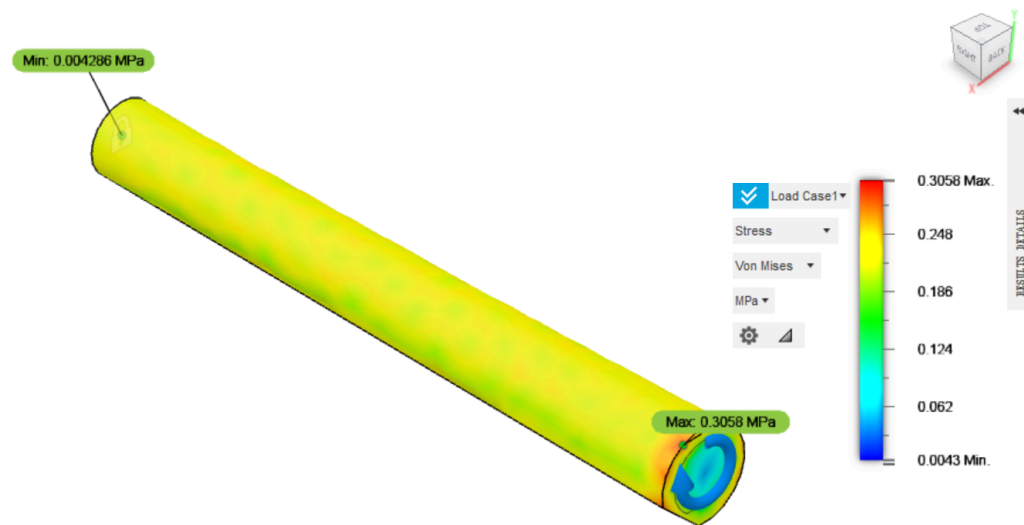


Figure 9: Stress Distribution in the Shaft

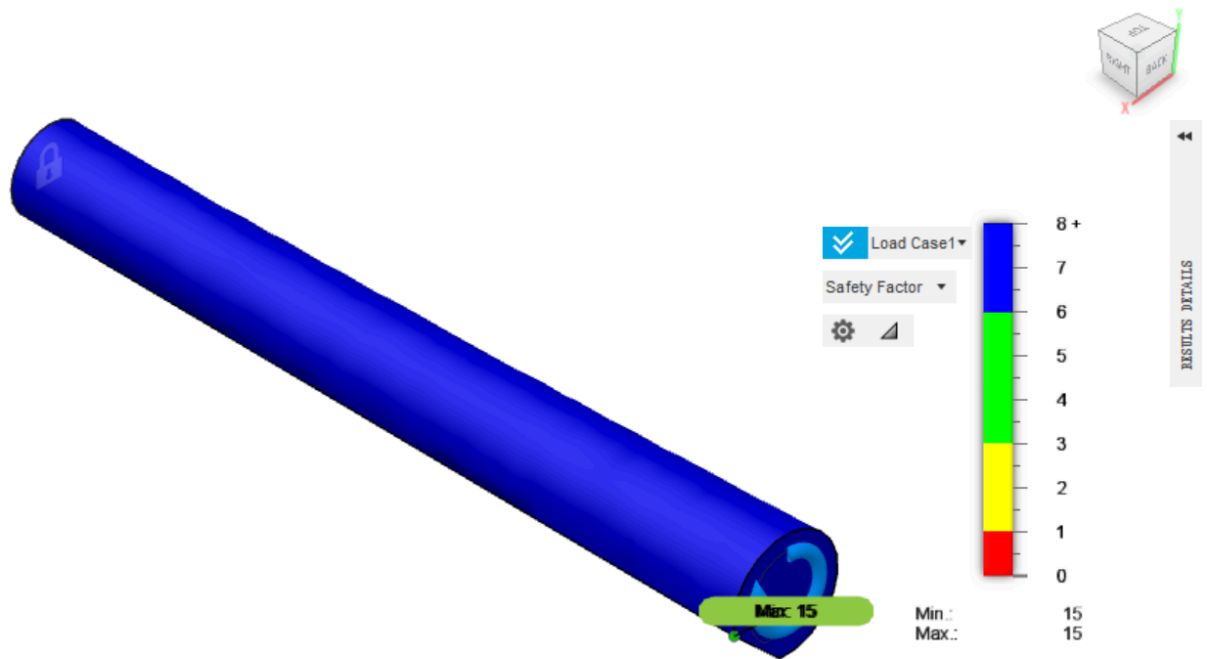


Figure 10: Safety Factor Evaluation at All Locations in the Shaft



Figure 21: Picture of Paper Prototype

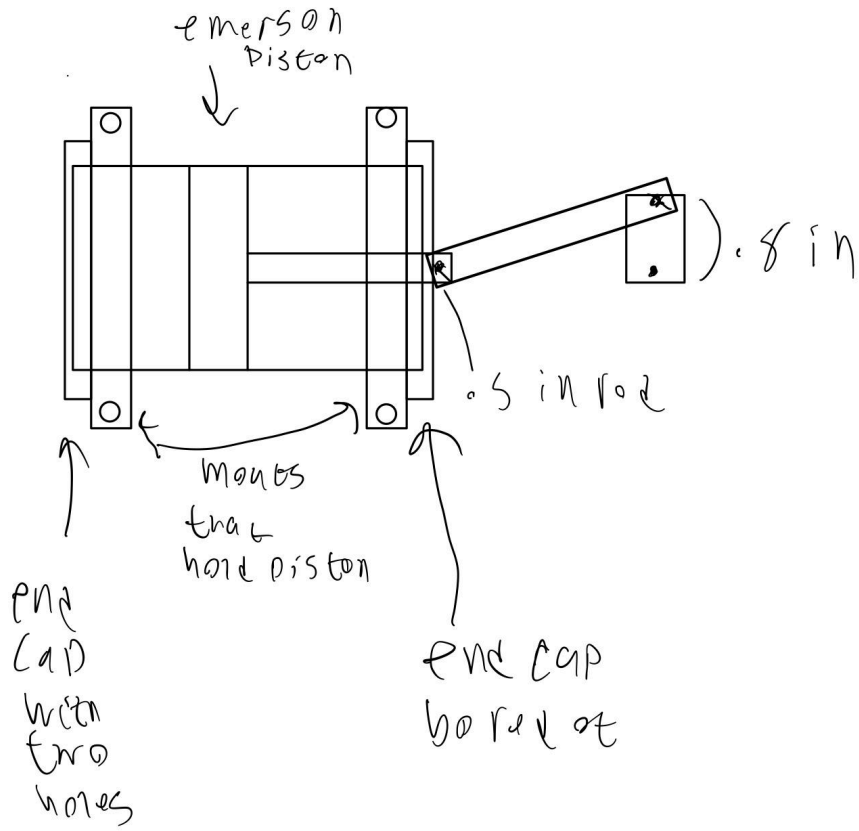


Figure 22: Preliminary Sketch of Piston Pump

Part Drawings

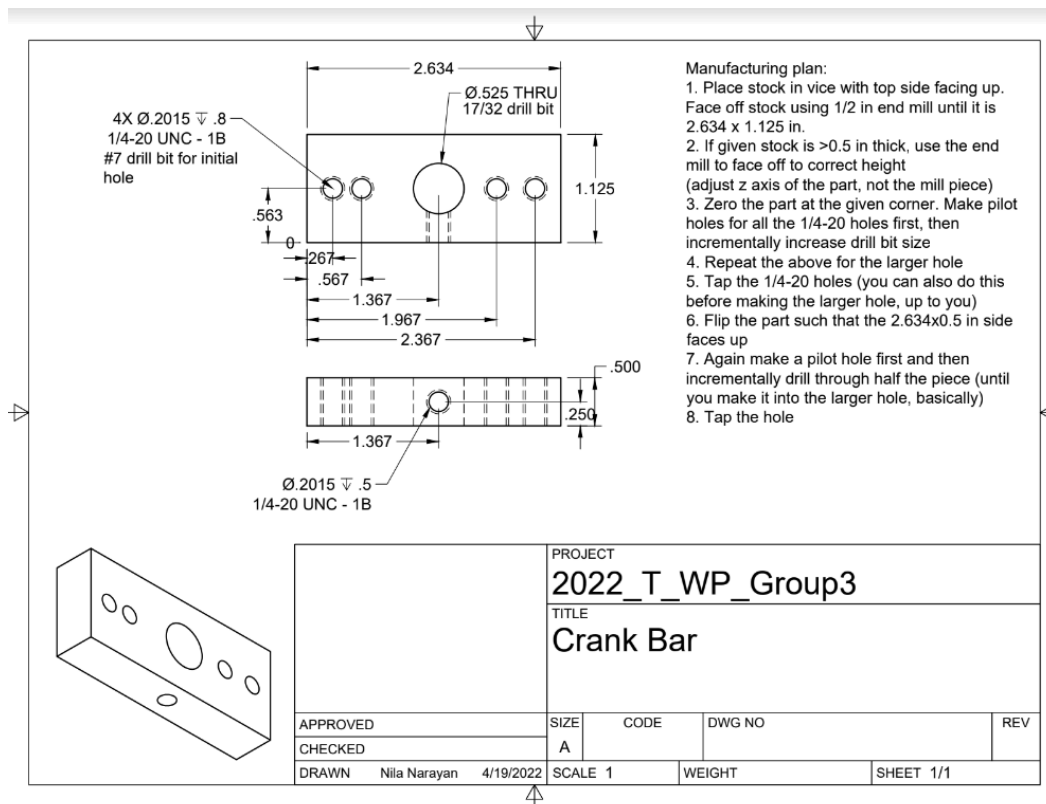


Figure 13: Adjustable Crank Bar. Machined on the mill.

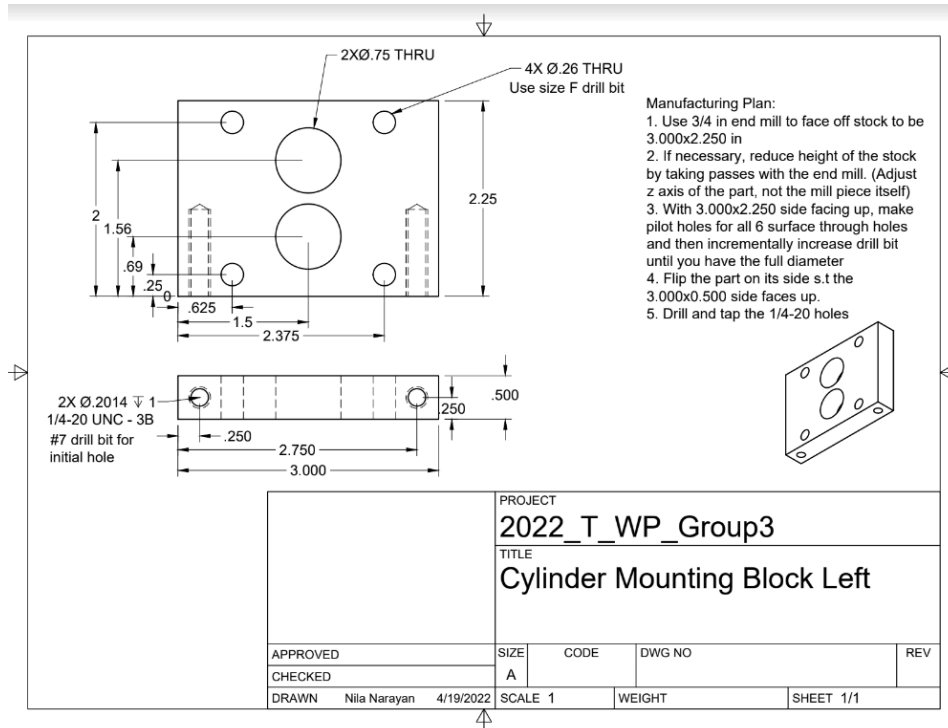


Figure 14: Left Piston Mounting Block. Machined on the mill.

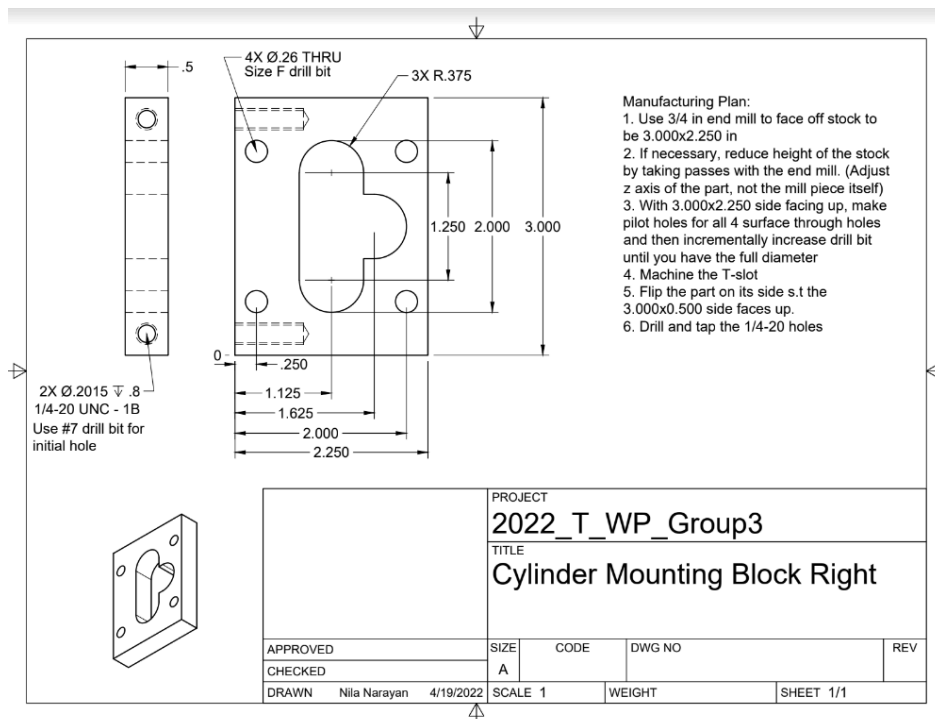


Figure 15: Right Piston Mounting Block. Machined on the mill

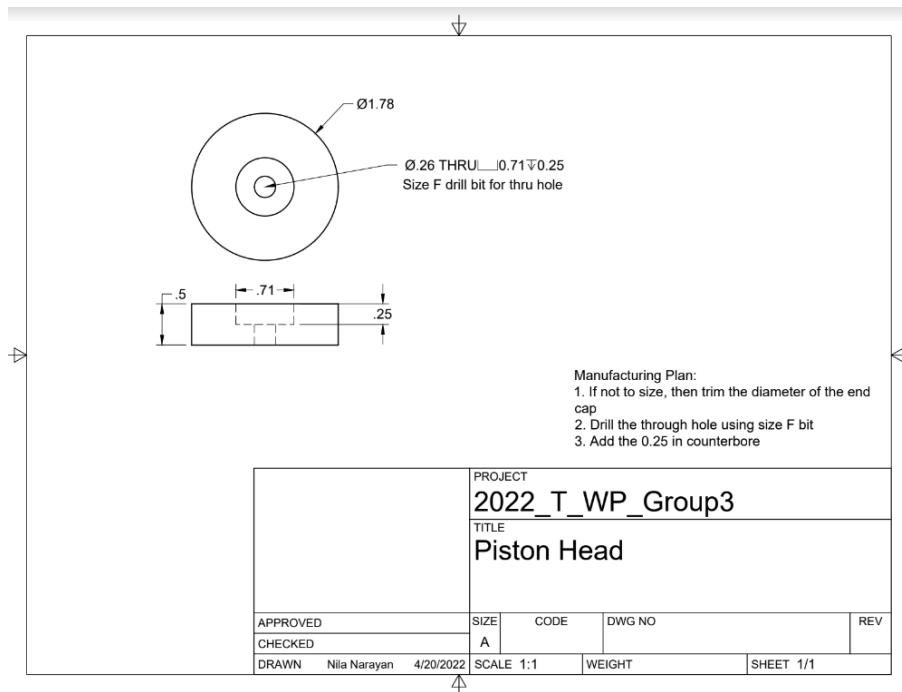


Figure 16: Piston Head (Initial, No O-Ring). Machined on the lathe.

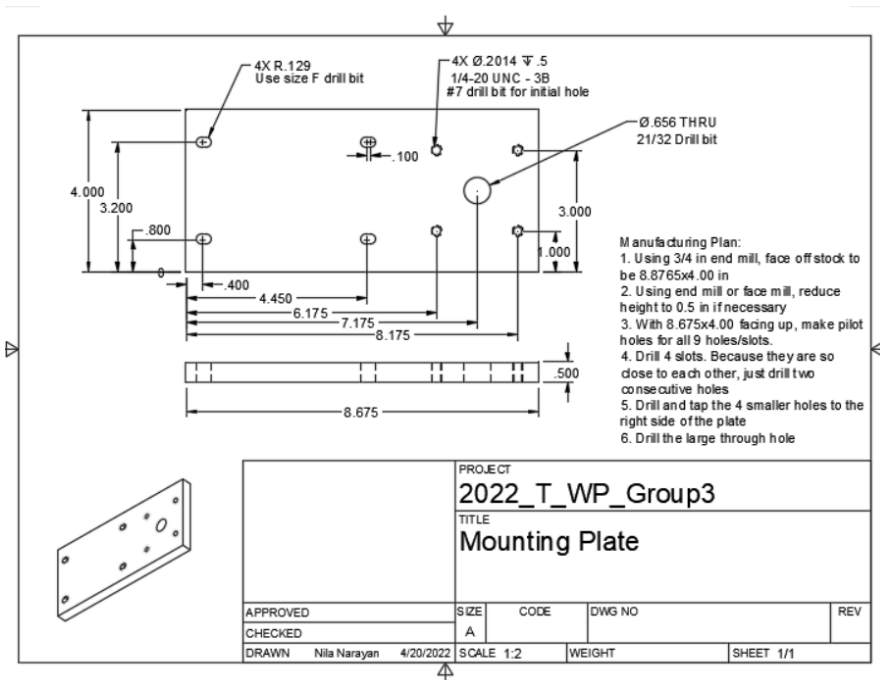


Figure 17: Mounting Plate. Fully machined on the mill.

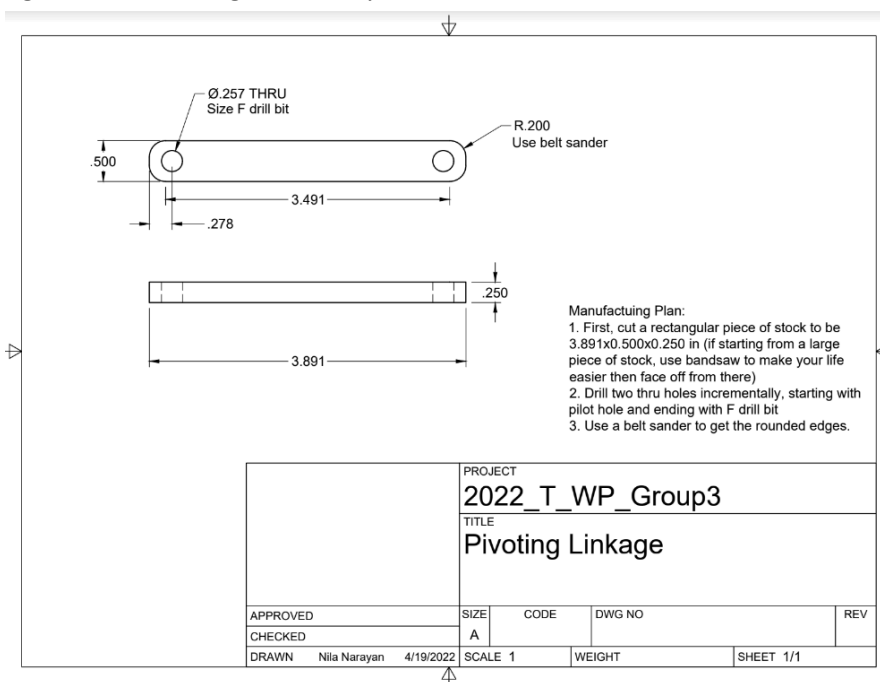


Figure 18: Pivoting Linkage. Machined on the mill, with radius added with a belt sander.

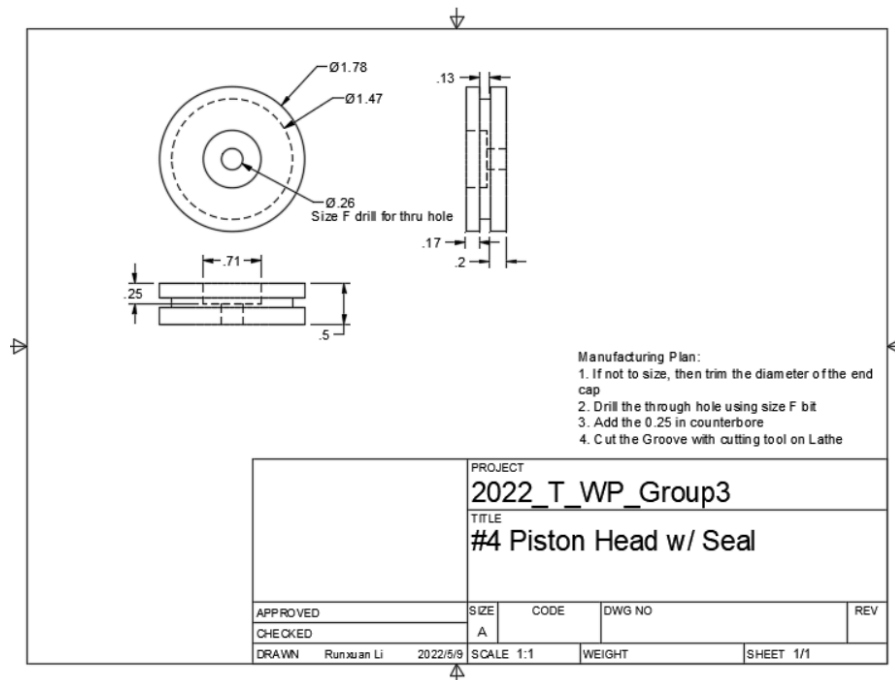


Figure 19: Modified Piston Head (with seal). Machined in the lathe.

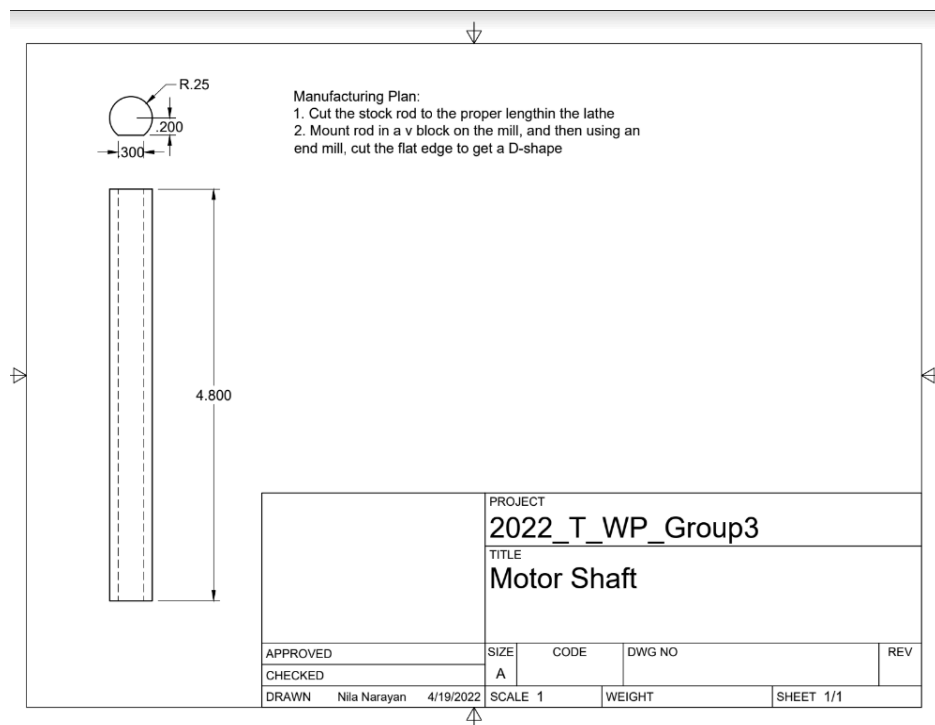


Figure 20: Motor shaft, machined on the lathe followed by the mill.

Other Calculations

Volumetric flow rate calculation:

ENJ&X

r = Radius of Crank, A = Cross sectional area

\dot{Q} = Volumetric flow rate, $\dot{\theta}$ = Angular velocity

$$\dot{Q} = \frac{RA\dot{\theta}}{\pi}, A = \pi\left(\frac{1.78}{2}in\right)^2$$

$$\dot{\theta} = \frac{9}{70} \cdot 900RPM = \frac{9 \cdot 900RPM}{70} \cdot 2\pi \frac{rad}{rotation} = 727.054 \frac{rad}{min}$$

$$\dot{Q} = r\left(\frac{1.78}{2}\right)^2 in^3 \cdot \frac{727.054}{min} = 575.9r \frac{in^3}{min}$$

$$\dot{Q} = 575.9r \frac{in^3}{min} \cdot \frac{1liter}{61.024in^3} = 9.44r \frac{liter}{min}$$

$$r = .6in, \dot{Q} = 5.66 \frac{liter}{min}, r = .8in, \dot{Q} = 7.55 \frac{liter}{min}$$

$$r = 1in, \dot{Q} = 9.44 \frac{liter}{min}, r = 1.1in, \dot{Q} = 10.38 \frac{liter}{min}$$

Torque and Force Calculations

$$\tau_{in} = 4.5lbft$$

$$\tau_{out} = \tau_{in} \frac{70}{9}$$

$$\tau_{out} = 4.5lbft \frac{70}{9} = 35lbft$$

$$\tau = F \cdot L$$

$$\tau_{out} = F \cdot r = F \cdot r \frac{ft}{12in} = F \frac{rft}{12}$$

$$F = \frac{\tau_{out}}{L} = \frac{35lbft}{\frac{rft}{12}} = \frac{420lb}{r} = \frac{420lb}{r} \frac{4.448N}{lb} = \frac{1868.2N}{r}$$

$$r = .6in, F = 3116.6N, r = .8in, F = 2335.2N,$$

$$r = 1in, F = 1868.2N, r = 1.1in, F = 1698.3N$$

Timelines and Team Calendar

In addition to the fabrication timeline shown above, the team used a general calendar to keep track of major deadlines, as shown below. This was drafted with the Team Charter and modified slightly as time went on. Mostly, we used the fabrication timeline as our driving timeline since the biggest time consumers were machining tasks. In general, we were able to stay on track with our original schedule by completing tasks as soon as we could. We ordered parts as soon as we had plans, started manufacturing as soon as we had drawings, and were good about making use of the lab time we had. As mentioned before, there was a mixup about the actual pump due date and we thought we would have more time for manufacturing than we did. However, given our simpler design and that strategy of proactiveness, we were able to complete our pump on time.

Date	Event/Milestone	Expectations
3/18/2022	Due 11:55pm: Team Charter	PDF submitted to Canvas
3/24/2022	Due EOD: Final Design	Complete drawings (hand or CAD) by the end of our Thursday meeting
3/31/2022	Due EOD: CAD/Sketches	Need CAD Model with renders, machining drawings for manufactured parts, and all purchased components in CAD
3/31/2022	Complete in meeting: Parts Order	Complete list of parts to order
3/31/2022	Submit Parts Order (in meeting)	Order all necessary components from McMaster
4/18/2022	First week of manufacturing	Decide who will manufacture each part Print out technical drawings for manufactured parts
4/19/2022	Water Pump Final design	A9 is due and the presentation will happen during lab A9 in Canvas
4/25/2022	Second week of manufacturing	Continue working on machining the parts and constructing the pump
5/1/2022	Final Week of manufacturing	Finish putting together the pump and performing tests
5/3/2022	Water Pump finished	A11 and A12 are due and the water pump must be completed

Notes on Team Charter

Our team charter was fairly standard, with the goal being to divide work equally while playing to individual strengths. We appointed “leads” for certain tasks like CAD, machining, and test day operations but the idea was for everyone to contribute to all these roles. We were able to stick to our weekly

meeting times and made good use of that time, with a few extra meetings thrown in closer to the end of the project to finalize some details. Our communication plan was to use group text messages and Google Drive, and this worked well since it gave everyone quick access and visibility. One problem we did have was that there were a few redundant documents in that Google Drive folder which served a similar purpose but held slightly different information. One example was our parts list, which ended up being in four or five different spreadsheets with slightly different names and counts for items. This led to some confusion that was eventually resolved, but it did cost us time to figure out.

With respect to team cooperation, all team members were very diligent about their individual responsibilities and we did not have to enact our "Missed Deadlines" clause at all. There were a couple of instances where someone needed help to finish on time, but they communicated this to the team and other members stepped up to help. Overall, we achieved our goal of sharing the workload while taking direction in certain areas from those with more experience and knowledge. As a result, we achieved our design goals for the water pump and were very pleased with the process and end result of this project.